



T1-BNCMBNCL

Flexible Cable Replacing Remi-rigid Cable Assembly

T1/BNC Male /BNC Male/DC-3 GHz

Features:

- Max Frequency 3 GHz
- VSWR max of 1.30
- Velocity of Propagation of 70%

Applications:

- Test & Measurement equipment
- Manufacturing lab
- WAN system equipment

Cable Cross Section:

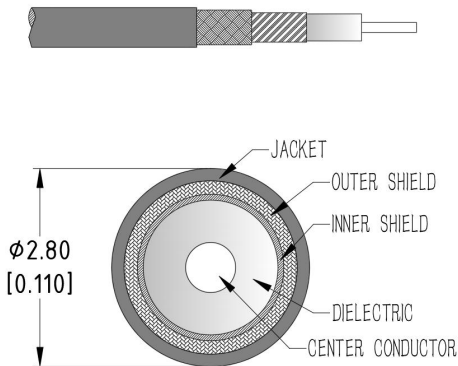

Electrical Characteristics:

Parameter	Min	Typ	Max	Units
Frequency Range	DC		3	GHz
VSWR		1.25	1.3	:1
Velocity of propagation		70%		
Shielding Effectiveness	90			dB
Capacitance			81	pF/m
Phase Stability Vs. Flexure@3GHz		±2		°
Amplitude Stability Vs. Flexure@3GHz		±0.03		dB

Environmental And Physical Characteristics:

Description	Parameter	Units
Cable Diameter	2.8	mm
Cable Jacket	FEP	
Min. Bending Radius	14	mm
Typical Flex life	50000	
Operating Temperature	-55 to +125	°C
Storage Temperature	-55 to +165	°C

Cable Performance By Frequency

Frequency	2 GHz	4 GHz	6 GHz
Insertion Loss (dB/m Max)	1.00	1.46	1.84
RF Power CW (W Max.)	69	47	38



T1-BNCMBNCM-L

Connectors:

Description	Connector 1	Connector 2
Type	BNC Straight Male	BNC Straight Male
Contact Material And Plating	Brass,Gold	Brass,Gold
Dielectric Type	PTFE	PTFE
Body Material And Plating	Beryllium Copper&Brass,Nikel	Beryllium Copper&Brass,Nikel
Insertion Loss (dB Max)	$0.05 * \sqrt{f_GHz}$	$0.05 * \sqrt{f_GHz}$

Outline Drawing:

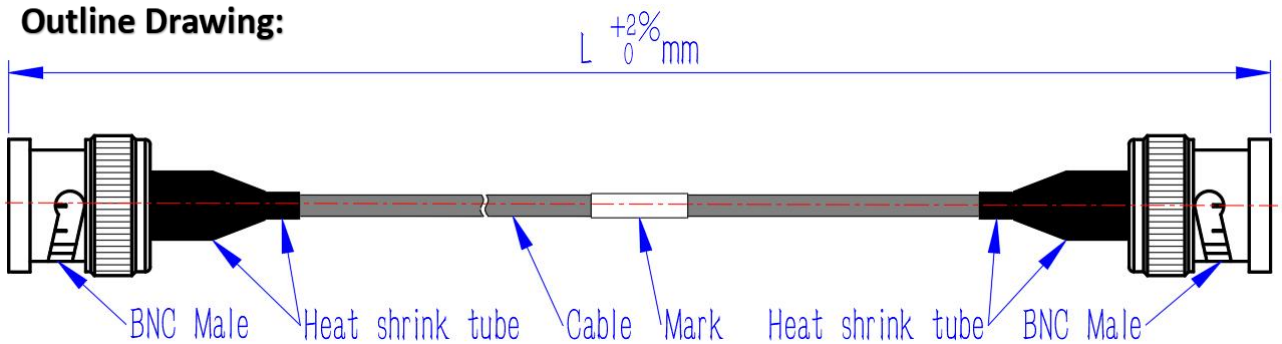

Ordering Information:

Base Number	Lenth (Unit meters)	Phase/delay Matched
T1-BNCMBNCM	-L	LEAVE BLANK(NOT REQUIRED) -XXPS($\leq \pm XX$ PS) -XX°($\pm XX^\circ$)

Typical Performance Data:

Model:T1-BNCMBNCM-1m

Frequency	0.5 GHz		1 GHz		2 GHz		3 GHz	
	Typ	Max	Typ	Max	Typ	Max	Typ	Max
Insertion Loss (dB)	0.52	0.55	0.74	0.79	1.07	1.14	1.34	1.42
VSWR	1.05	1.1	1.15	1.20	1.20	1.25	1.25	1.30