



# T1-NMTNCM-L

## Flexible Ultra Low Loss Coax Cable Assembly

T1/N Male /TNC Male/DC-18 GHz

### Features:

- Max Frequency 18 GHz
- VSWR max of 1.30
- Velocity of Propagation of 70%

### Applications:

- Test & Measurement equipment
- Manufacturing lab
- WAN system equipment

### Cable Cross Section:

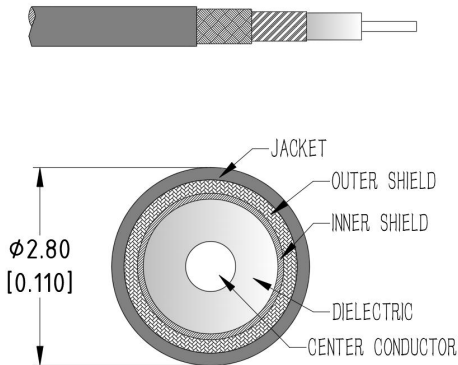

### Electrical Characteristics:

Parameter	Min	Typ	Max	Units
Frequency Range	DC		18	GHz
VSWR		1.25	1.3	:1
Velocity of propagation		70%		
Shielding Effectiveness	90			dB
Capacitance			81	pF/m
Phase Stability Vs. Flexure		±8	±10	°
Amplitude Stability Vs. Flexure		±0.10	±0.20	dB
Phase Stability Vs. Temperature			1100	PPM

### Environmental And Physical Characteristics:

Description	Parameter	Units
Cable Diameter	2.8	mm
Cable Jacket	FEP	
Min. Bending Radius	14	mm
Typical Flex life	50000	
Operating Temperature	-55 to +125	°C
Storage Temperature	-55 to +125	°C

### Cable Performance By Frequency

Frequency	2 GHz	4 GHz	6 GHz	8 GHz	12 GHz	16 GHz	18 GHz	26.5 GHz	40GHz
Insertion Loss (dB/m Max )	1.00	1.46	1.84	2.16	2.74	3.24	3.48	4.41	5.71
RF Power CW (W Max.)	69	47	38	32	25	21	20	16	12

## Connectors:

Description	Connector 1	Connector 2
Type	N Straight Male	TNC Straight Male
Contact Material And Plating	Brass,Gold	Brass,Gold
Dielectric Type	PTFE	PTFE
Body Material And Plating	Passivated Stainless Steel	Passivated Stainless Steel
Insertion Loss (dB Max)	$0.05 * \sqrt{f\_GHz}$	$0.05 * \sqrt{f\_GHz}$

## Outline Drawing:

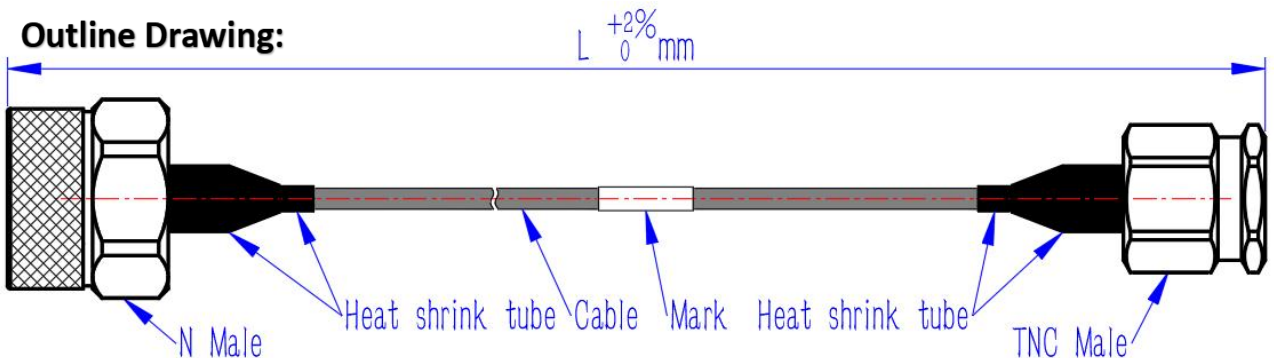

## Ordering Information:

Base Number	Lenth (Unit meters)	Armour	Phase/delay Matched
T1-NMTNCM	-L	<b>LEAVE BLANK(NOT REQUIRED)</b> -A(默认黑色尼龙铠甲) -AS(不锈钢铠甲) -AP(PUR防水铠甲) -AT(透明铠甲)	<b>LEAVE BLANK(NOT REQUIRED)</b> -XXPS( $\pm XX$ PS) -XX°( $\pm XX$ °)

## Typical Performance Data:

Model:T1-NMTNCM-1m

Frequency	2 GHz		6 GHz		12 GHz		18 GHz	
	Typ	Max	Typ	Max	Typ	Max	Typ	Max
Insertion Loss	1.07	1.14	1.96	2.08	2.91	3.08	3.69	3.91
VSWR	1.05	1.1	1.15	1.20	1.20	1.25	1.25	1.30

