



# T1-2.92M2.92M-L

## Flexible Cable Replacing Remi-rigid Cable Assembly

T1/2.92mm Male /2.92mm Male/DC-40 GHz



### Features:

- Max Frequency 40 GHz
- VSWR max of 1.30
- Velocity of Propagation of 70%

### Applications:

- Test & Measurement equipment
- Manufacturing lab
- WAN system equipment

### Cable Cross Section:

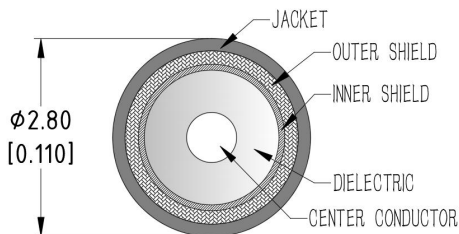

### Electrical Characteristics:

Parameter	Min	Typ	Max	Units
Frequency Range	DC		40	GHz
VSWR		1.25	1.3	:1
Velocity of propagation		70%		
Shielding Effectiveness	90			dB
Capacitance			81	pF/m
Phase Stability Vs. Flexure@40GHz		±8		°
Amplitude Stability Vs. Flexure@40GHz		±0.10		dB

### Environmental And Physical Characteristics:

Description	Parameter	Units
Cable Diameter	2.8	mm
Cable Jacket	FEP	
Min. Bending Radius	14	mm
Typical Flex life	50000	
Operating Temperature	-55 to +125	°C
Storage Temperature	-55 to +165	°C

### Cable Performance By Frequency:

Frequency	2 GHz	4 GHz	6 GHz	8 GHz	12 GHz	16 GHz	18 GHz	26.5 GHz	40GHz
Insertion Loss (dB/m Max )	1.00	1.46	1.84	2.16	2.74	3.24	3.48	4.41	5.71
RF Power CW (W Max.)	69	47	38	32	25	21	20	16	12



# T1-2.92M2.92M-L

## Connectors:

Description	Connector 1	Connector 2
Type	2.92mm Straight Male	2.92mm Straight Male
Contact Material And Plating	Beryllium Copper,Gold	Beryllium Copper,Gold
Dielectric Type	PEI	PEI
Body Material And Plating	Passivated Stainless Steel	Passivated Stainless Steel
Insertion Loss (dB Max)	$0.05 * \sqrt{f\_GHz}$	$0.05 * \sqrt{f\_GHz}$

## Outline Drawing:

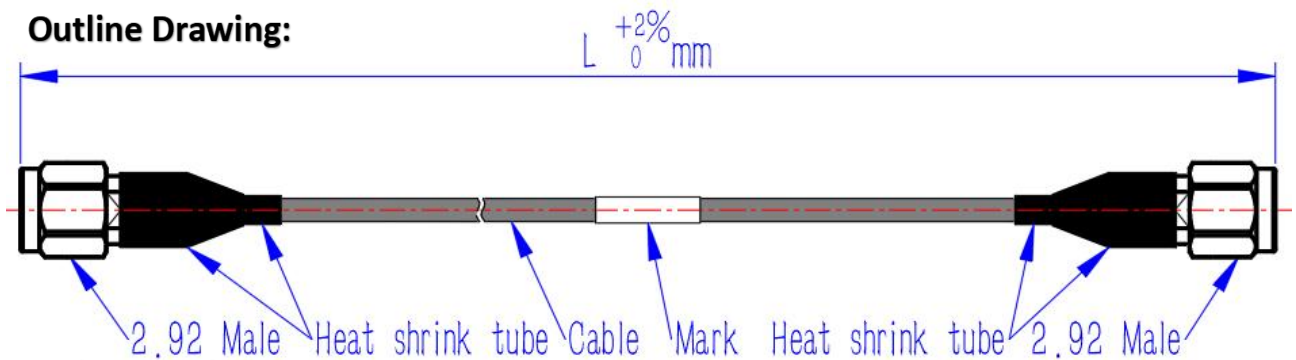

## Ordering Information:

Base Number	Length (Unit meters)	Phase/delay Matched
T1-2.92M2.92M	-L	LEAVE BLANK(NOT REQUIRED) -XXPS( $\leq \pm XX$ PS) -XX°( $\pm XX^\circ$ )

## Typical Performance Data:

Model:T1-2.92M2.92M-1m

Frequency	2 GHz		6 GHz		12 GHz		18 GHz		26.5 GHz		40GHz	
	Typ	Max	Typ	Max	Typ	Max	Typ	Max	Typ	Max	Typ	Max
Insertion Loss (dB)	1.07	1.14	1.96	2.08	2.91	3.08	3.69	3.91	4.67	4.92	6.02	6.34
VSWR	1.05	1.1	1.08	1.15	1.1	1.2	1.15	1.2	1.2	1.30	1.25	1.30