



# R2-SMAWMSMAWM-L

## R Series Semi-flexible Cable Assemblies

### R2/SMA Right Angle Male /DC-18 GHz

#### Features:

- Max Frequency 18 GHz
- VSWR max of 1.30
- Velocity of Propagation of 70%

#### Applications:

- Test & Measurement equipment
- Manufacturing lab
- WAN system equipment

#### Electrical Characteristics:

Parameter	Min	Typ	Max	Units
Frequency Range	DC		18	GHz
VSWR		1.25	1.3	:1
Velocity of propagation		70%		
Shielding Effectiveness	90			dB
Capacitance			81	pF/m

#### Cable Cross Section:

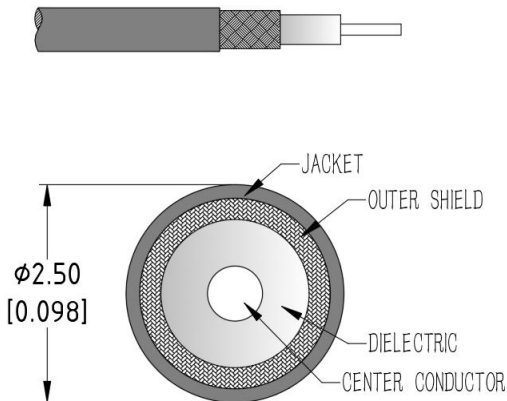

#### Environmental And Physical Characteristics:

Description	Parameter	Units
Cable Diameter	2.5	mm
Cable Jacket	FEP	
Min. Bending Radius	11	mm
Typical Flex life	50000	
Operating Temperature	-55 to +125	°C
Storage Temperature	-55 to +165	°C

#### Cable Performance By Frequency

Frequency	2 GHz	4 GHz	6 GHz	8 GHz	12 GHz	16 GHz	18 GHz
Insertion Loss (dB/m Max )	1.00	1.46	1.84	2.16	2.74	3.24	3.48
RF Power CW (W Max.)	69	47	38	32	25	21	20



# R2-SMAWMSMAWM-L

## Connectors:

Description	Connector 1	Connector 2
Type	SMA Right Angle Male	SMA Right Angle Male
Contact Material And Plating	Beryllium Copper,Gold	Beryllium Copper,Gold
Dielectric Type	PTFE	PTFE
Body Material And Plating	Passivated Stainless Steel	Passivated Stainless Steel
Insertion Loss (dB Max)	$0.05 * \sqrt{f\_GHz}$	$0.05 * \sqrt{f\_GHz}$

## Outline Drawing:

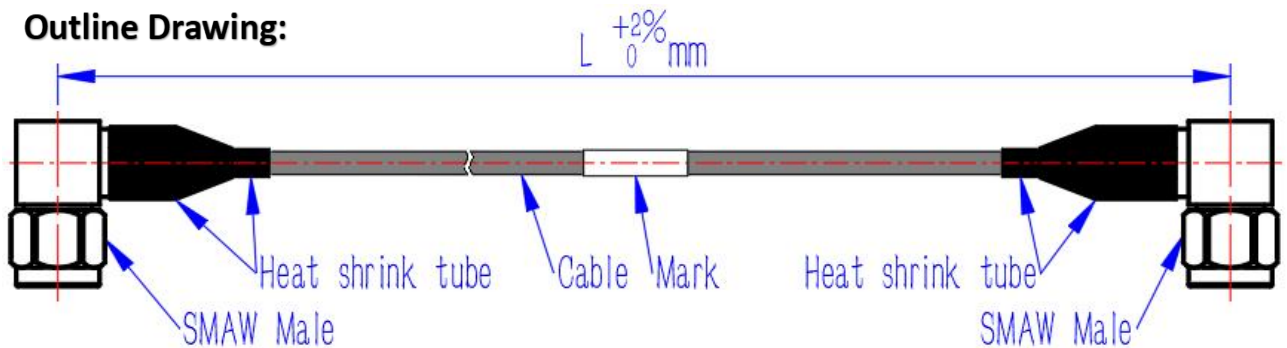

## Ordering Information:

Base Number	Length (Unit meters)	Phase/delay Matched
R2-SMAWMSMAWM	-L	LEAVE BLANK(NOT REQUIRED) -XXPS( $\leq \pm XX$ PS) -XX°( $\pm XX^\circ$ )

## Typical Performance Data:

Model:R2-SMAWMSMAWM-1m

Frequency	2 GHz		6 GHz		12 GHz		18 GHz	
	Typ	Max	Typ	Max	Typ	Max	Typ	Max
Insertion Loss	1.07	1.14	1.96	2.08	2.91	3.08	3.69	3.91
VSWR	1.05	1.10	1.08	1.15	1.15	1.20	1.25	1.30