



# S1-NMNWM-L

## Flexible Low Loss Phase Stable Flexible Sable Assemblies

S1/N Male /N Right Angle Male/DC-18 GHz

### Features:

- Max Frequency 18 GHz
- VSWR max of 1.30
- Velocity of Propagation of 76%

### Applications:

- Test & Measurement equipment
- Manufacturing lab
- WAN system equipment

### Cable Cross Section:

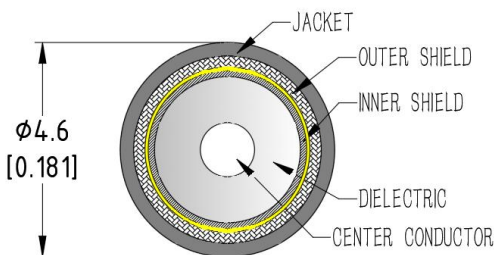

### Electrical Characteristics:

Parameter	Min	Typ	Max	Units
Frequency Range	DC		18	GHz
VSWR		1.25	1.3	:1
Velocity of propagation		76%		
Shielding Effectiveness	90			dB
Capacitance			87.7	pF/m
Phase Stability Vs. Flexure@18GHz		±3		°
Amplitude Stability Vs. Flexure@18GHz		±0.03		dB
Phase Stability Vs. Temperature		1000		PPM

### Environmental And Physical Characteristics:

Description	Parameter	Units
Cable Diameter	4.6	mm
Cable Jacket	FEP	
Min. Bending Radius	23	mm
Typical Flex life	50000	
Operating Temperature	-55 to +165	°C
Storage Temperature	-55 to +200	°C

### Cable Performance By Frequency

Frequency	1 GHz	2 GHz	4 GHz	6 GHz	8 GHz	12 GHz	16GHz	18 GHz
Insertion Loss (dB/m Max )	0.35	0.50	0.72	0.89	1.16	1.28	1.49	1.58
RF Power CW (W Max.)	569	400	280	227	174	158	136	127

## Connectors:

Description	Connector 1	Connector 2
Type	N Straight Male	N Right Angle Male
Contact Material And Plating	Brass,Gold	Beryllium Copper,Gold
Dielectric Type	PTFE	PTFE
Body Material And Plating	Passivated Stainless Steel	Passivated Stainless Steel
Insertion Loss (dB Max)	$0.05 * \sqrt{f\_GHz}$	$0.05 * \sqrt{f\_GHz}$

## Outline Drawing:

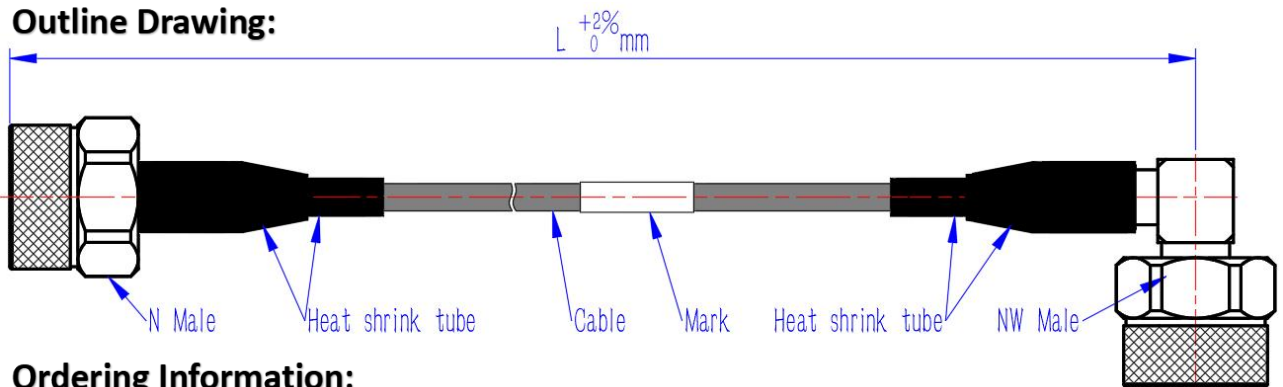

## Ordering Information:

Base Number	Length (Unit meters)	Armour	Phase/delay Matched
S1-NMNWM	-L	<b>LEAVE BLANK(NOT REQUIRED)</b> -A(默认黑色尼龙铠甲) -AS(不锈钢铠甲) -AP(PUR防水铠甲) -AT(透明铠甲)	<b>LEAVE BLANK(NOT REQUIRED)</b> -XXPS( $\leq \pm XX$ PS) -XX°( $\pm XX^\circ$ )

## Typical Performance Data:

Model:S1-NMNWM-1m

Frequency	2 GHz		6 GHz		12 GHz		18 GHz	
	Typ	Max	Typ	Max	Typ	Max	Typ	Max
Insertion Loss (dB)	0.57	0.64	1.00	1.13	1.45	1.62	1.79	2.01
VSWR	1.03	1.05	1.05	1.10	1.15	1.20	1.20	1.25

