



# A22-1.85F2.4M-L

## Flexible Ultra Low Loss Coax Cable Assembly

A22/1.85mm Female /2.4mm Male/DC-50 GHz



### Features:

- Max Frequency 50 GHz
- VSWR max of 1.30
- Velocity of Propagation of 82%

### Applications:

- Test & Measurement equipment
- Manufacturing lab
- WAN system equipment

### Cable Cross Section:

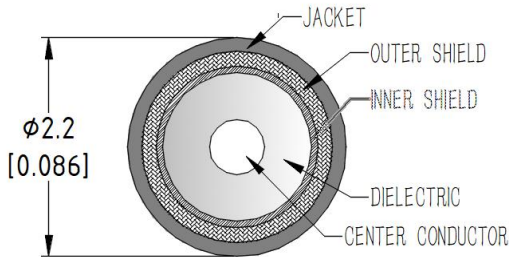

### Electrical Characteristics:

Parameter	Min	Typ	Max	Units
Frequency Range	DC		50	GHz
VSWR		1.25	1.3	:1
Velocity of propagation		82%		
Shielding Effectiveness	90			dB
Capacitance			81	pF/m
Phase Stability Vs. Flexure@50GHz		±5		°
Amplitude Stability Vs. Flexure@50GHz		±0.08		dB
Phase Stability Vs. Temperature			550	PPM

### Environmental And Physical Characteristics:

Description	Parameter	Units
Cable Diameter	2.2	mm
Cable Jacket	FEP	
Min. Bending Radius	11	mm
Typical Flex life	50000	
Operating Temperature	-55 to +125	°C
Storage Temperature	-55 to +165	°C

### Cable Performance By Frequency:

Frequency	2 GHz	4 GHz	6 GHz	8 GHz	12 GHz	18 GHz	26.5 GHz	40GHz	50 GHz
Insertion Loss (dB/m Max )	0.91	1.30	1.60	1.86	2.31	2.87	3.54	4.44	5.03
RF Power CW (W Max.)	190	133	108	82	75	60	49	39	34



# A22-1.85F2.4M-L

## Connectors:

Description	Connector 1	Connector 2
Type	1.85mm Straight Female	2.4mm Straight Male
Contact Material And Plating	Beryllium Copper,Gold	Beryllium Copper,Gold
Dielectric Type	PEI	PEI
Body Material And Plating	Passivated Stainless Steel	Passivated Stainless Steel
Insertion Loss (dB Max)	$0.05 * \sqrt{f\_GHz}$	$0.05 * \sqrt{f\_GHz}$

## Outline Drawing:

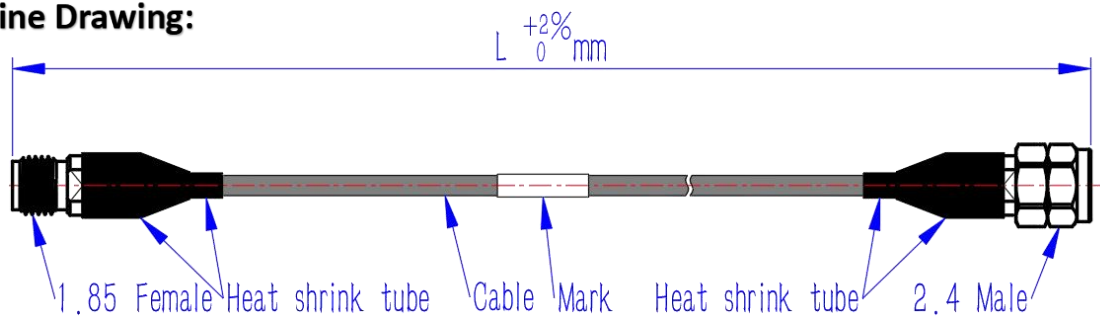

## Ordering Information:

Base Number	Length (Unit meters)	Armour	Phase/delay Matched
A22-1.85F2.4M	-L	<b>LEAVE BLANK(NOT REQUIRED)</b> -A(默认黑色尼龙铠甲) -AS(不锈钢铠甲) -AP(PUR防水铠甲) -AT(透明铠甲)	<b>LEAVE BLANK(NOT REQUIRED)</b> -XXPS( $\pm XX$ PS) -XX°( $\pm XX^\circ$ )

## Typical Performance Data:

Model:A22-1.85F2.4M-1m

Frequency	2 GHz		6 GHz		12 GHz		18 GHz		26.5 GHz		40GHz		50GHz	
	Typ	Max	Typ	Max	Typ	Max	Typ	Max	Typ	Max	Typ	Max	Typ	Max
Insertion Loss (dB)	0.98	1.05	1.73	1.85	2.48	2.66	3.08	3.29	3.80	4.05	4.76	5.07	5.38	5.74
VSWR	1.03	1.05	1.05	1.08	1.08	1.10	1.10	1.15	1.15	1.20	1.20	1.25	1.25	1.30

