



SP7T to SP8T Electromechanical Switch

Normally Open , DC to 26.5 GHz, 2.92mm, TTL, D-SUB

Electrical Characteristics:

Parameter	Value
Frequency Range	DC-26.5 GHz
RF Impedance	50 Ohms
Operation Mode	Normally Open
TTL TTL Voltage	0-0.8 V(OFF) 2.4-5 V(ON)
Switch Sequence	Break before make
Switching time	15 ms Max
Standard Actuator Life	2 million (min)
Actuator Voltage Available	12 24 28 V
Actuator current	260 130 100 mA



RF Specifications:

Frequency (GHz)	DC-4	4-8	8-12.4	12.4-18	18-26.5
Insertion Loss (dB max.)	0.2	0.3	0.4	0.6	0.8
Isolation (dB min.)	75	65	60	60	55
VSWR (max.)	1.2:1	1.3:1	1.4:1	1.6:1	1.8:1
RF Power CW (Watts max.)	100	70	60	45	15

Environmental And Physical Characteristics:

Parameter	Value
Operating Temperature	-25°C to +65°C(Standard) -55°C - +85°C(Optional)
Vibration(operating)	10G RMS, 20-2000HZ
Shock(non operating)	50G, 1/2Sine, 12msec
Connector Type	2.92mm Female
Control Connector	D-SUB 15 PIN Male
Weight	300g Max



SP7T to SP8T Electromechanical Switch

Outline Drawing:

Unit: Inch(mm)

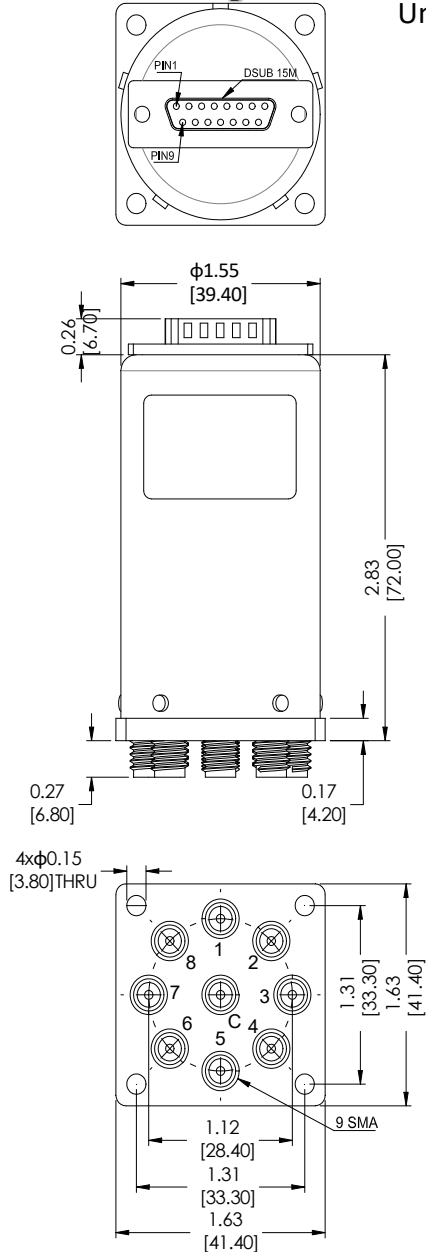

Schematic:

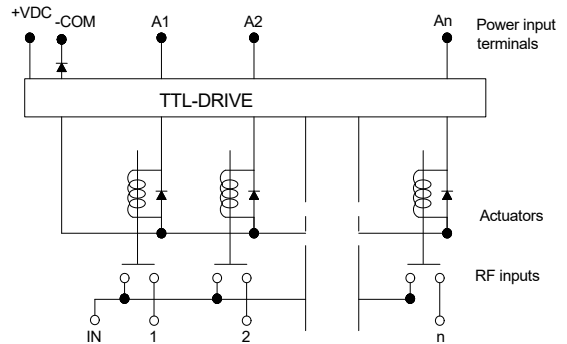

Pin NO	FUNCTION	RF Connect Used	
		SP7T	SP8T
1	A1	1	1
2	A2	2	2
3	A3	3	3
4	A4	4	4
5	A5	5	5
6	A6	6	6
7	A7	7	7
8	A8		8
9	-COM		
10	NC		
11	NC		
12	NC		
13	NC		
14	NC		
15	+VDC		

Part Number:

Part Number		Actuator voltage	Option
SP7T	SP8T		
R17-KN12T26-D	R18-KN12T26-D	12 V	-S (-55°C - +85°C)
R17-KN24T26-D	R18-KN24T26-D	24 V	
R17-KN28T26-D	R18-KN28T26-D	28 V	