



SPDT Electromechanical Switch

Pulse Latching, DC to 40 GHz, TTL, 2.92mm, Terminated, D-SUB

Electrical Characteristics:

Parameter	Condition
Frequency Range	DC-40GHz
RF Impedance	50 Ohms
Operation Mode	Pulse Latching
Switch Sequence	Break before make
Switching time	15 ms Max
Standard Actuator Life	5 million Min
TTL Voltage	0-0.8 V(OFF) 2.4-5 V(ON)
Actuator voltage Available	12 24 28 V
Actuator current	200 100 80 mA
Termination Power CW	2 W



RF Specifications:

Frequency (GHz)	DC-6	6-12	12-18	18-26.5	26.5-40
Insertion Loss (dB max.)	0.20	0.25	0.40	0.70	1.00
Isolation (dB min.)	70	70	60	55	50
VSWR (max.)	1.2:1	1.3:1	1.4:1	1.7:1	2.0:1
RF Power CW (Watts max.)	80	50	45	15	8

Environmental And Physical Characteristics:

Parameter	Condition
Operating Temperature	-25°C to +65°C (Standard) -55°C to +85°C (Optional)
Vibration (operating)	10G RMS, 20-2000HZ
Shock (non operating)	50G, 1/2Sine, 12msec
Connector Type	2.92mm Female
Control Connector	D-SUB 9PIN Male
Weight	100g Max



SPDT Electromechanical Switch

Outline Drawing:

Unit: Inch(mm)

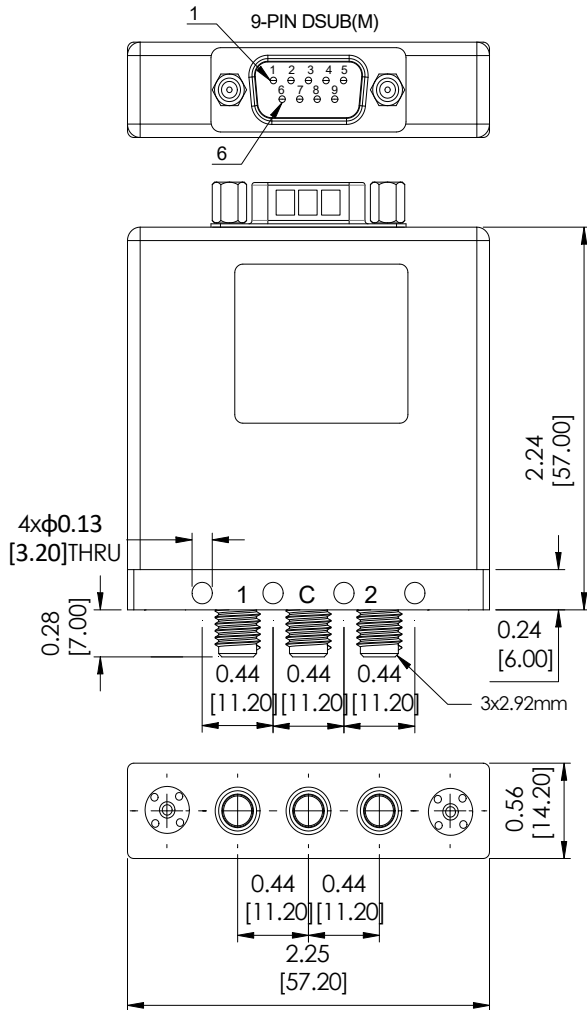

Schematic:

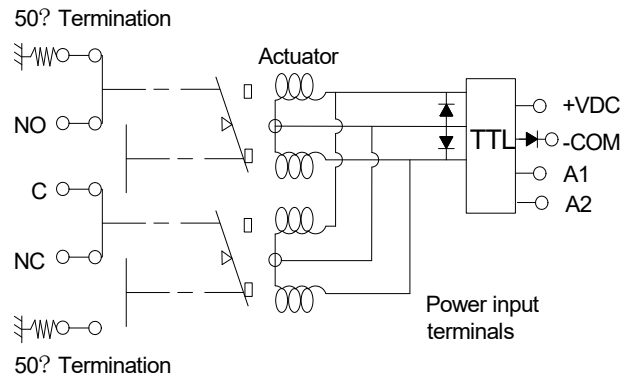

9 PIN D-SUB		RF Connect Used
Pin NO	FUNCTION	SP2T
1	A1	J1-COM
2	A2	J2-COM
3	-COM	
4	NC	
5	NC	
6	NC	
7	NC	
8	NC	
9	+VDC	

Outline Drawing:

Model	Actuator voltage	Option
R12-KL12T40-DT	12 V	-S(-55°C - +85°C)
R12-KL24T40-DT	24 V	
R12-KL28T40-DT	28 V	



SPDT Electromechanical Switch

Typical Performance Data:

INSERTION LOSS

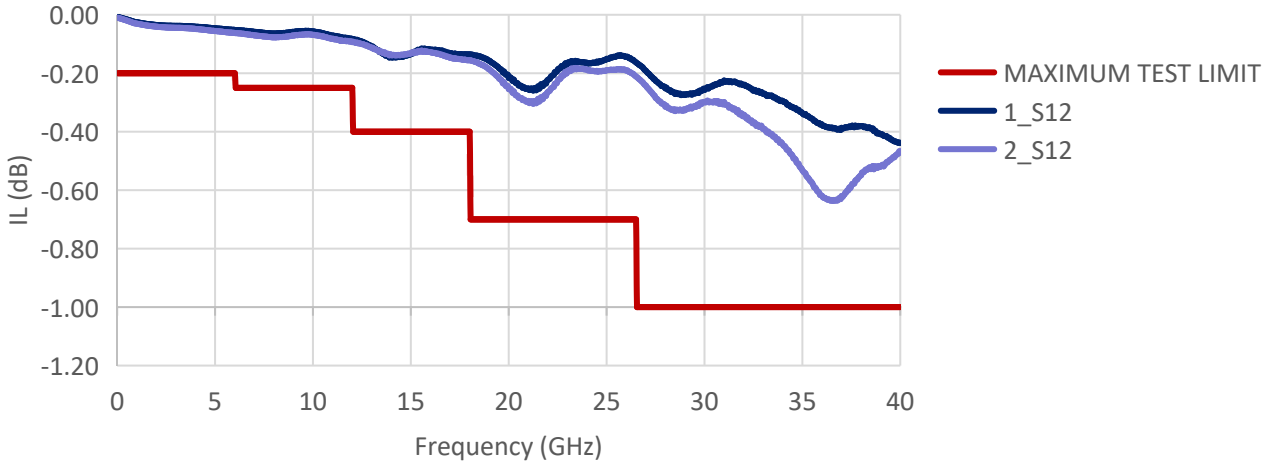

VSWR

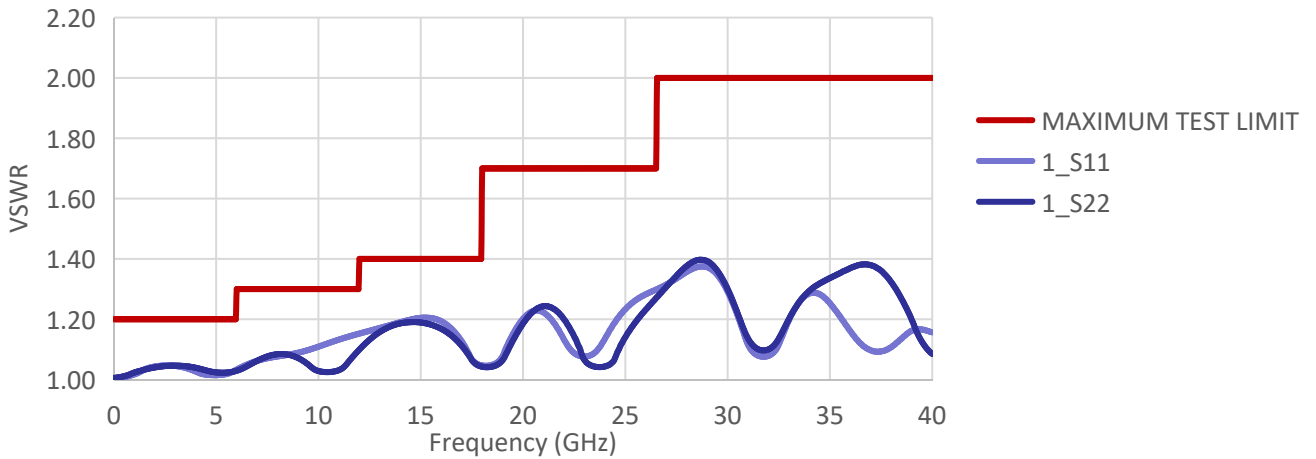

ISOLATION

