



SPDT Electromechanical Switch

Pulse Latching, DC to 18 GHz, TTL, SMA, Terminated, Solder Pin

Electrical Characteristics:

Parameter	Condition
Frequency Range	DC-18 GHz
RF Impedance	50 Ohms
Operation Mode	Pulse Latching
Switch Sequence	Break before make
Switching time	15 ms Max
Standard Actuator Life	5 million Min
TTL Voltage	0-0.8 V(OFF) 2.4-5 V(ON)
Actuator voltage Available	12 24 28 V
Actuator current	200 100 80 mA
Termination Power CW	2 W



RF Specifications:

Frequency (GHz)	DC-6	6-12	12-18
Insertion Loss (dB max.)	0.2	0.25	0.4
Isolation (dB min.)	70	70	60
VSWR (max.)	1.2:1	1.3:1	1.4:1
RF Power CW (Watts max.)	80	60	50

Environmental And Physical Characteristics:

Parameter	条件 Condition
Operating Temperature	-25°C to +65°C(Standard) -55°C to +85°C(Optional)
Vibration(operating)	10G RMS, 20-2000HZ
Shock(non operating)	50G, 1/2Sine, 12msec
Connector Type	SMA Female
Control Connector	Solder Pin
Weight	100g Max



SPDT Electromechanical Switch

Outline Drawing:

Unit: Inch(mm)

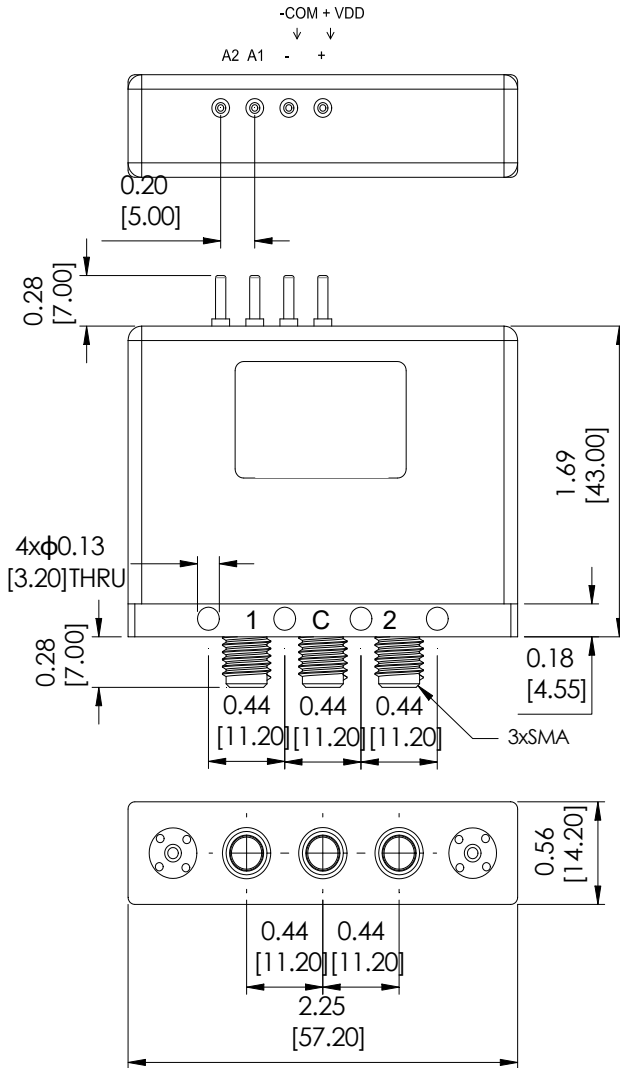

Schematic:

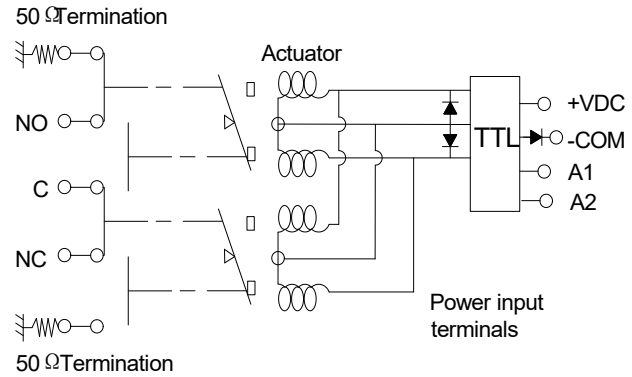

Outline Drawing:

Model	Actuator voltage	Option
R12-SL12T18-T	12 V	-S(-55°C - +85°C)
R12-SL24T18-T	24 V	
R12-SL28T18-T	28 V	



SPDT Electromechanical Switch

Typical Performance Data:

INSERTION LOSS

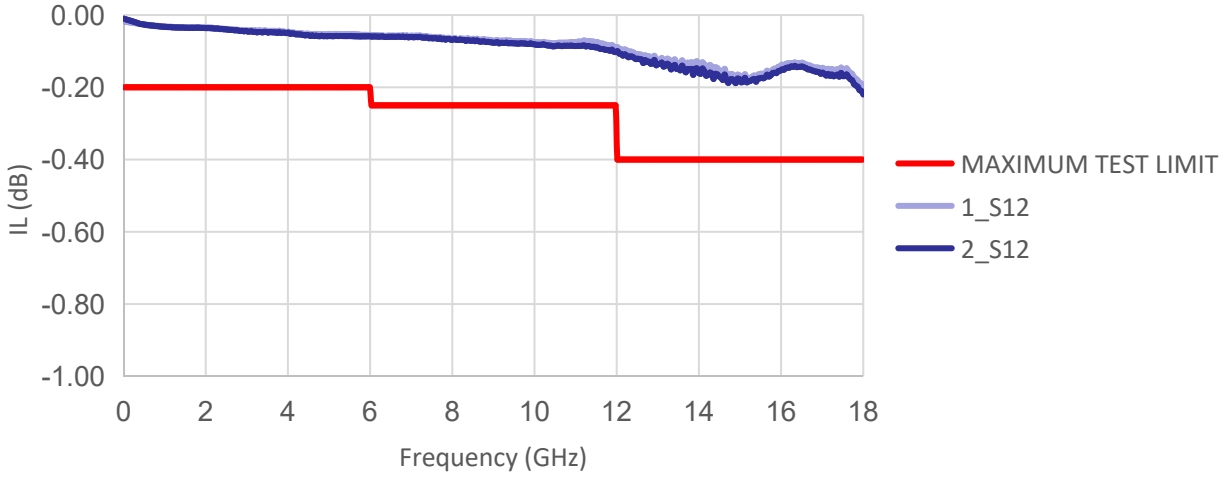

VSWR

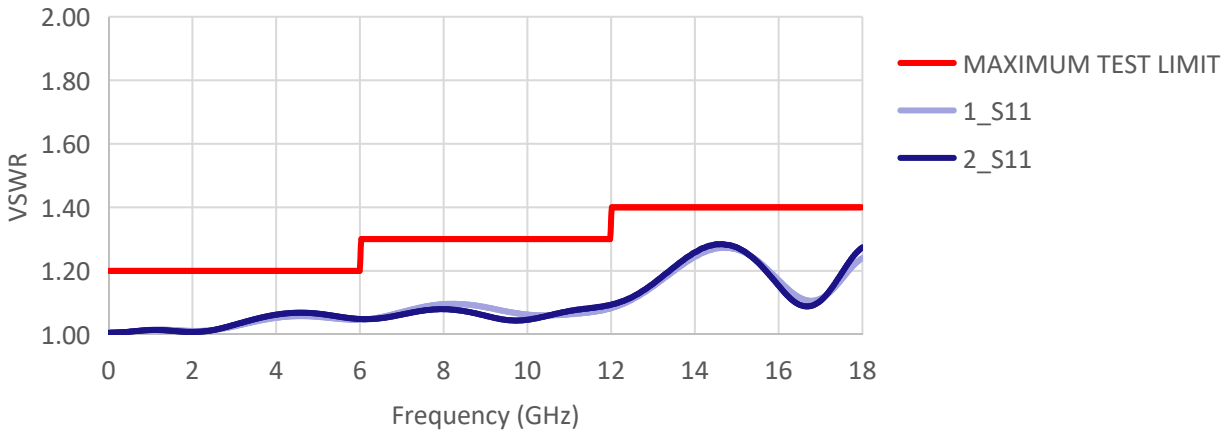

ISOLATION

