



SPDT Electromechanical Switch

Failsafe, DC to 18 GHz, TTL, SMA, Indicators, Terminated, D-SUB

Electrical Characteristics:

Parameter	Condition
Frequency Range	DC-18GHz
RF Impedance	50 Ohms
Operation Mode	Failsafe
Switch Sequence	Break before make
Switching time	15 ms Max
Standard Actuator Life	5 million Min
TTL Voltage	0-0.8 V(OFF) 2.4-5 V(ON)
Actuator voltage Available	12 24 28 V
Actuator current	200 100 80 mA
Indicator Specifications	Max withstand voltage: 60V Max current capacity: 100mA Max "ON" resistance: 16Ω
Termination Power CW	2 W



RF Specifications:

Frequency (GHz)	DC-6	6-12	12-18
Insertion Loss (dB max.)	0.2	0.25	0.4
Isolation (dB min.)	70	70	60
VSWR (max.)	1.2:1	1.3:1	1.4:1
RF Power CW (Watts max.)	80	60	50

Environmental And Physical Characteristics:

Parameter	Condition
Operating Temperature	-25°C to +65°C (Standard) -55°C - +85°C (Optional)
Vibration (operating)	10G RMS, 20-2000HZ
Shock (non operating)	50G, 1/2 Sine, 12msec
Connector Type	SMA Female
Control Connector	D-SUB 9PIN Male
Weight	100g Max

Outline Drawing:

Unit: Inch(mm)

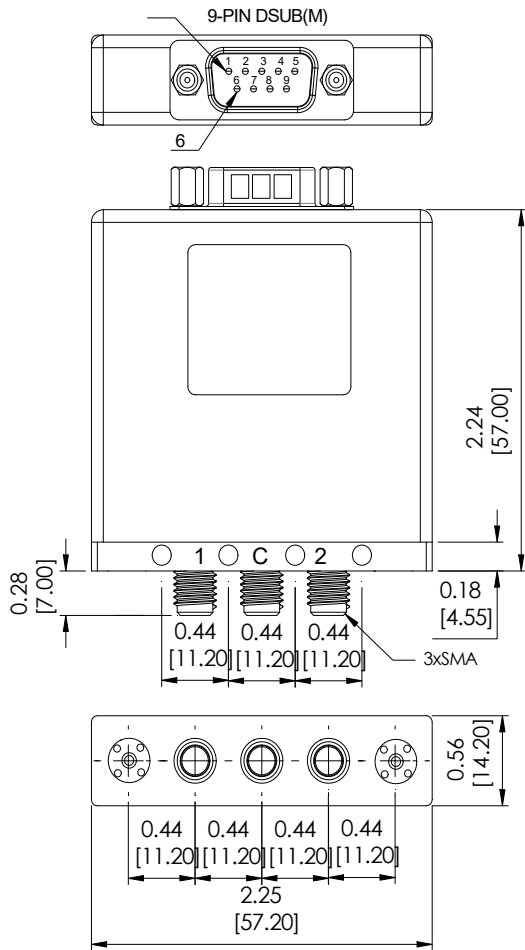

Schematic:

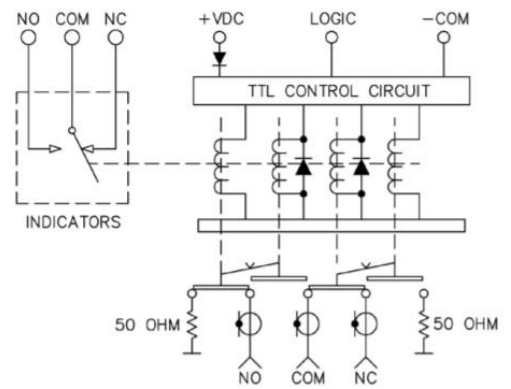

9 PIN D-SUB		RF Connect Used
Pin NO	FUNCTION	SP2T
1	LOGIC	1 (NO)
2	NC	
3	-COM	
4	NC	
5	iNO	
6	iNC	
7	iCOM	
8	NC	
9	+VDC	

Outline Drawing:

Model	Actuator voltage	Option
R12-SF12T18-DTI	12 V	-S(-55°C - +85°C)
R12-SF24T18-DTI	24 V	
R12-SF28T18-DTI	28 V	



SPDT Electromechanical Switch

Typical Performance Data:

INSERTION LOSS

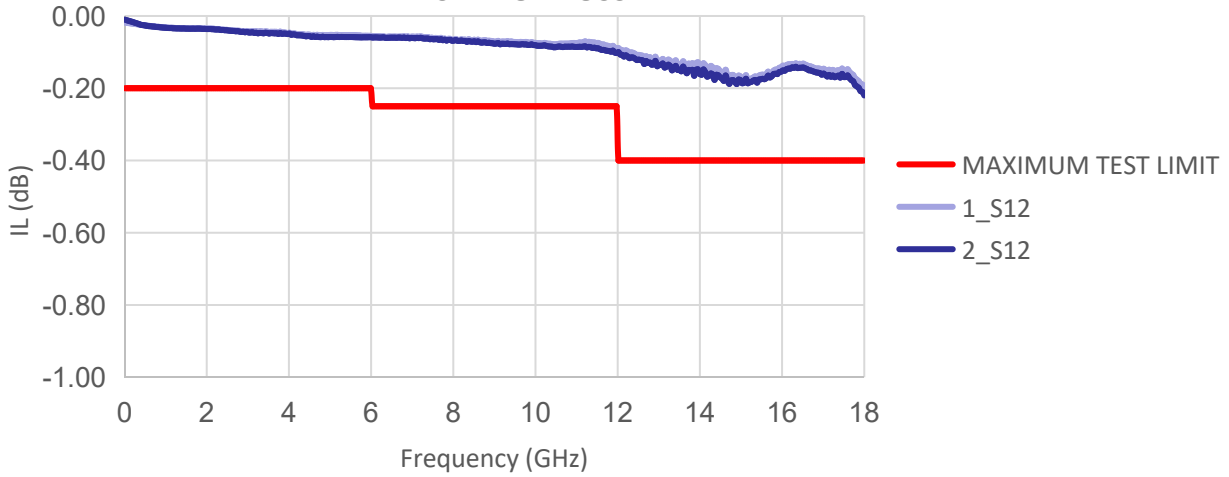

VSWR

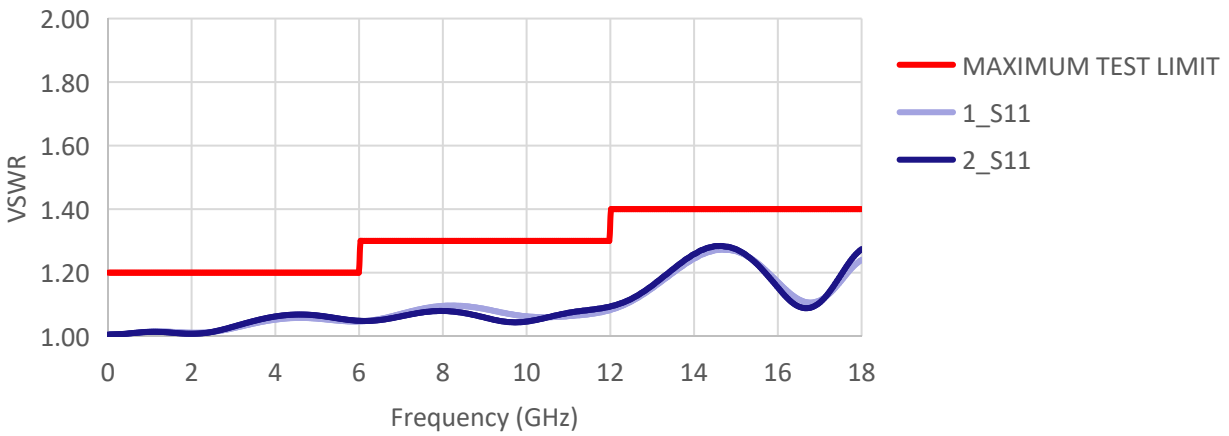

ISOLATION

