



## SP3T to SP6T Electromechanical Switch

Normally Open , DC to 18 GHz, SMA, TTL, Indicators, Terminated D-SUB

### Electrical Characteristics:

Parameter	Value
Frequency Range	DC-18 GHz
RF Impedance	50 Ohms
Operation Mode	Normally Open
TTL TTL Voltage	0-0.8 V(OFF) 2.4-5 V(ON)
Termination Power CW	2 W
Switch Sequence	Break before make
Switching time	15 ms Max
Standard Actuator Life	2 million Min
Actuator Voltage Available	12 24 28 V
Actuator current	300 160 140mA
Indicator Specifications	Max withstand voltage: 60V Max current capacity: 100mA Max "ON" resistance: 16Ω



### RF Specifications:

Frequency (GHz)	DC-6	6-12	12-18
Insertion Loss (dB max.)	0.3	0.4	0.5
Isolation (dB min.)	80	70	60
VSWR (max.)	1.3:1	1.4:1	1.5:1
RF Power CW (Watts max.)	80	50	45

### Environmental And Physical Characteristics:

Parameter	Value
Operating Temperature	-25°C to +65°C(Standard ) -55°C - +85°C(Optional)
Vibration(operating)	10G RMS, 20-2000HZ
Shock(non operating)	50G, 1/2Sine, 12msec
Connector Type	SMA Female
Control Connector	D-SUB 15 PIN Male
Weight	350g Max



# SP3T to SP6T Electromechanical Switch

## Outline Drawing:

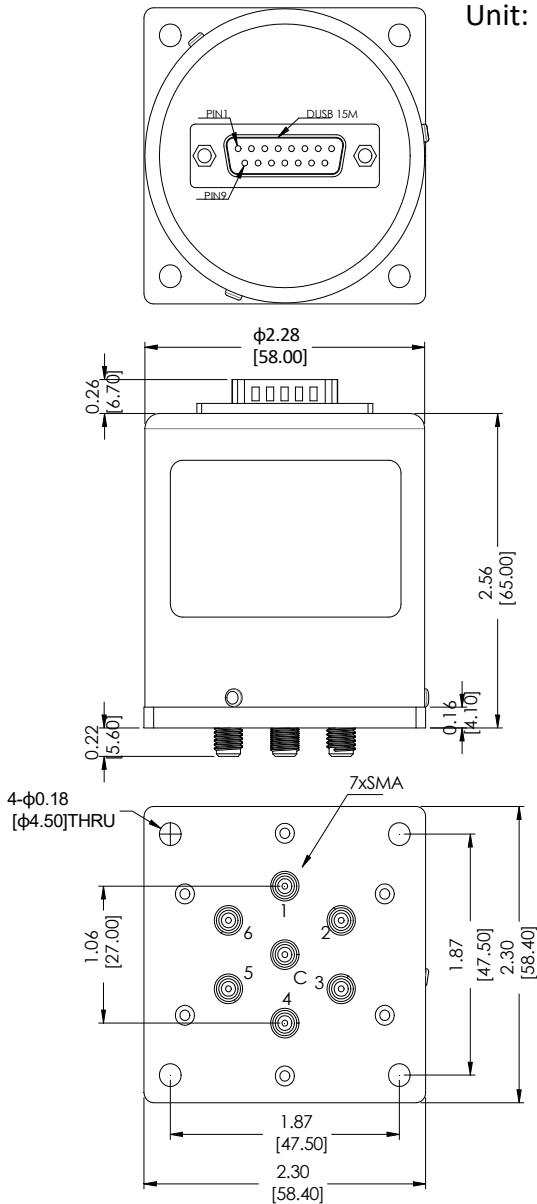

## Schematic

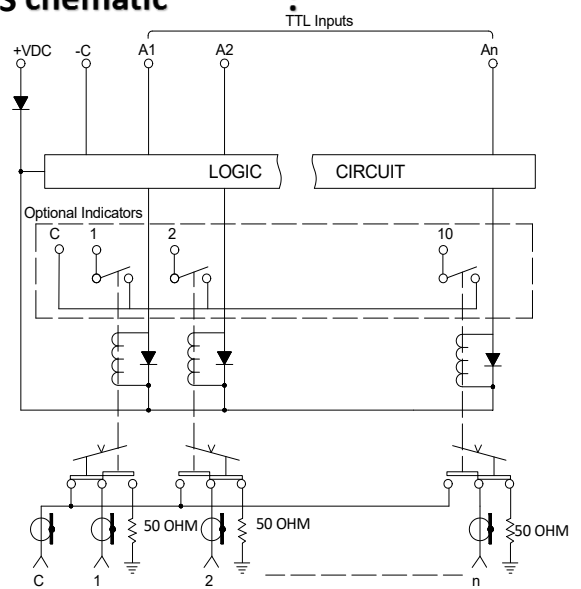

Pin NO	FUNCTION	RF Connect Used			
		SP3T	SP4T	SP5T	SP6T
1	A1	1	1	1	1
2	A2		2	2	2
3	A3	3		3	3
4	A4		4	4	4
5	A5	5	5	5	5
6	A6				6
7	-COM				
8	IND1	1	1	1	1
9	IND2		2	2	2
10	IND3	3		3	3
11	IND4		4	4	4
12	IND5	5	5	5	5
13	IND6				6
14	IND COM				
15	+VDC/+VDCI				

## Part Number:

Part Number				Actuator voltage	Option
SP3T	SP4T	SP5T	SP6T		
R13-SN12T18-DTI	R14-SN12T18-DTI	R15-SN12T18-DTI	R16-SN12T18-DTI	12 V	-S(-55°C +85°C)
R13-SN24T18-DTI	R14-SN24T18-DTI	R15-SN24T18-DTI	R16-SN24T18-DTI	24 V	
R13-SN28T18-DTI	R14-SN28T18-DTI	R15-SN28T18-DTI	R16-SN28T18-DTI	28 V	



# SP3T to SP6T Electromechanical Switch

## Typical Performance Data:

