



Pulse Latching, DC to 18 GHz, SMA, D-SUB

Electrical Characteristics:

Parameter	条件Condition
Frequency Range	DC-18GHz
RF Impedance	50 Ohms
Operation Mode	Pulse Latching
Switch Sequence	Break before make
Switching time	15 ms Max
Standard Actuator Life	2 million Min
Actuator voltage Available	12 24 28 V
Actuator current	380 200 180 mA



RF Specifications:

Frequency (GHz)	DC-6	6-12	12-18
Insertion Loss (dB max.)	0.2	0.3	0.4
Isolation (dB min.)	70	70	60
VSWR (max.)	1.3:1	1.4:1	1.5:1
RF Power CW (Watts max.)	80	60	50

Environmental And Physical Characteristics:

Parameter	Condition
Operating Temperature	-25°C to +65°C (Standard) -55°C to +85°C (Optional)
Vibration (operating)	10G RMS, 20-2000HZ
Shock (non operating)	50G, 1/2 Sine, 12msec
Connector Type	SMA Female
Control Connector	D-SUB 9Pin Male
Weight	120g Max



DPDT Electromechanical Switch

Outline Drawing:

Unit: Inch(mm)

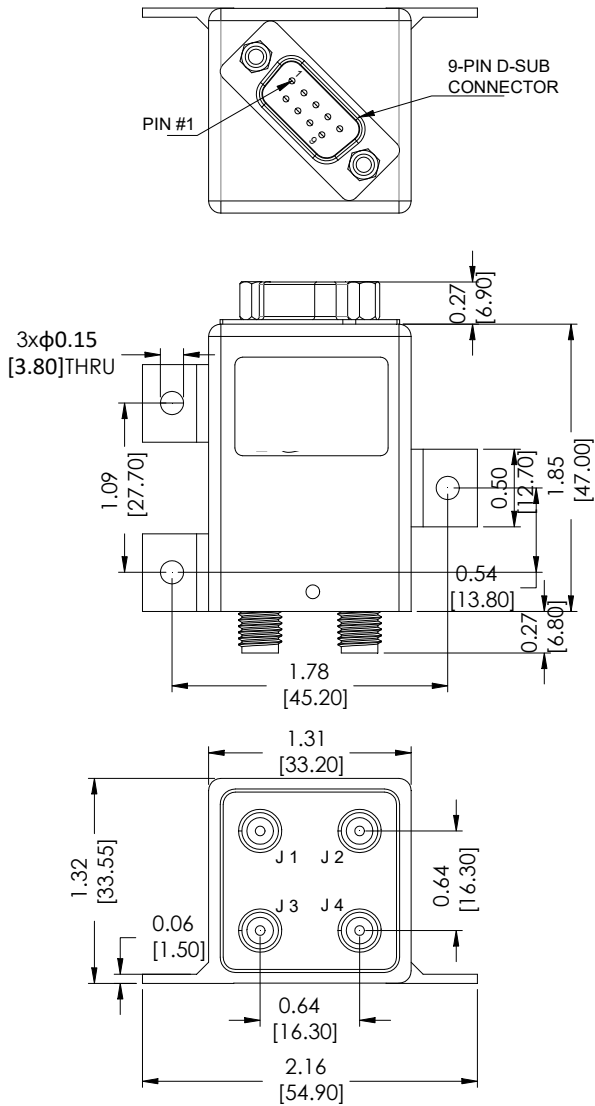

Schematic:

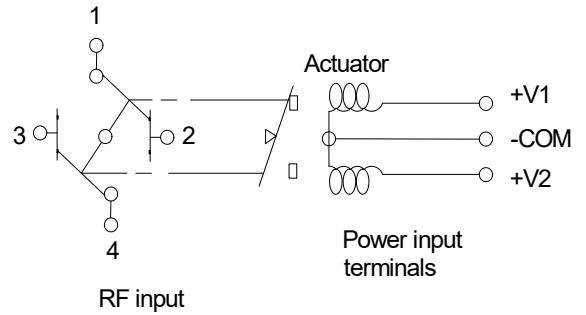

9 PIN D-SUB		RF Connect Used
Pin NO	FUNCTION	DPDT
1	V1	POS1:J1-J3,J2-J4
2	V2	POS2:J1-J2,J3-J4
3	-COM	
4	NC	
5	NC	
6	NC	
7	NC	
8	NC	
9	NC	

Outline Drawing:

Part Number	Actuator voltage	Option
R22-SL12018-D	12 V	-S(-55°C - +85°C)
R22-SL24018-D	24 V	
R22-SL28018-D	28 V	



DPDT Electromechanical Switch

Typical Performance Data:

